

Product

Description	Electric Strike and Proximity Card Reader with Antenna Module Mounted Separately in Frame
Dimensions	See pages 5-7
Orientation	Non-handed
Compatibility	Open Architecture
Access Control Systems	Interfaces with Wiegand Protocol Systems
Proximity Cards	Supports HID 26-39 Bit Formats
Frequency	Supports HID 125 kHz Credentials
Indicators	Red/Green LED and Buzzer
Supervision	Door Position Switch and Latchbolt Monitor

Applications

Frames	Steel, Aluminum, Wood
Trim Enhancer	Included
Locks	Cylindrical
Latchbolts Released*	Accommodates 1/2"-5/8" latchbolts (5/8" with 1/8" door gap)
Environment	Suitable for Exterior Doors
Temperature	-32° F to 150° F (-35° C to 65° C)
Humidity	5 - 95%, Non-condensing

Electrical

Reader Module	
Operating Voltage	12VDC +/- 20%
Operating Current	125 mA Max. @ 12VDC
Electric Strike Module	
Operating Voltage	12VDC +/- 10%
Operating Current	240 mA max. @ 12VDC

Cable detail

Reader Module	
Distance to Host	500 ft. Max.
Recommended Type	18-22 AWG (Dependent on Distance) Stranded and Shielded
Electric Strike Module	
Distance to Power	See Page 4
Recommended Type	See Page 4

Certifications

Compliance	FCC Part 15/IC Class B
Security	ANSI/BHMA 156.31, Grade 1
U.L. 10C-3 Hour Fire (RF8310 Only)	See Product Spec Listing

Warranty

Lifetime Warranty against defects in materials and workmanship
--

*Faceplate options accommodate various keeper and latchbolt actions. For more detail, contact HES tech support at 800-626-7590

Product Components

RF8010/RF8310: EXTERNAL ANTENNA

- ① Hybrid Electric Strike
- ② Door Position Switch, Press-Fit Magnet and 10" Connector Cable (2 Pin)
- ③ Pigtail Connectors (8 pin, 4 pin & 2 pin)
8 pin-Prox & Data
4 pin-Strike Power
2 pin-DPS and LBM
- ④ Faceplate (sold separately)
- ⑤ #12-24 Mounting Screws (included with faceplate)
- ⑥ #8-32 Faceplate Screws (included with faceplate)
- ⑦ Dielectric Grease (for humid applications)
- ⑧ 24" Cable (connecting reader/antenna and strike)
- ⑨ Reader/Antenna Body
- ⑩ #6-32 Reader/Antenna Screws
- ⑪ Reader/Antenna Cover

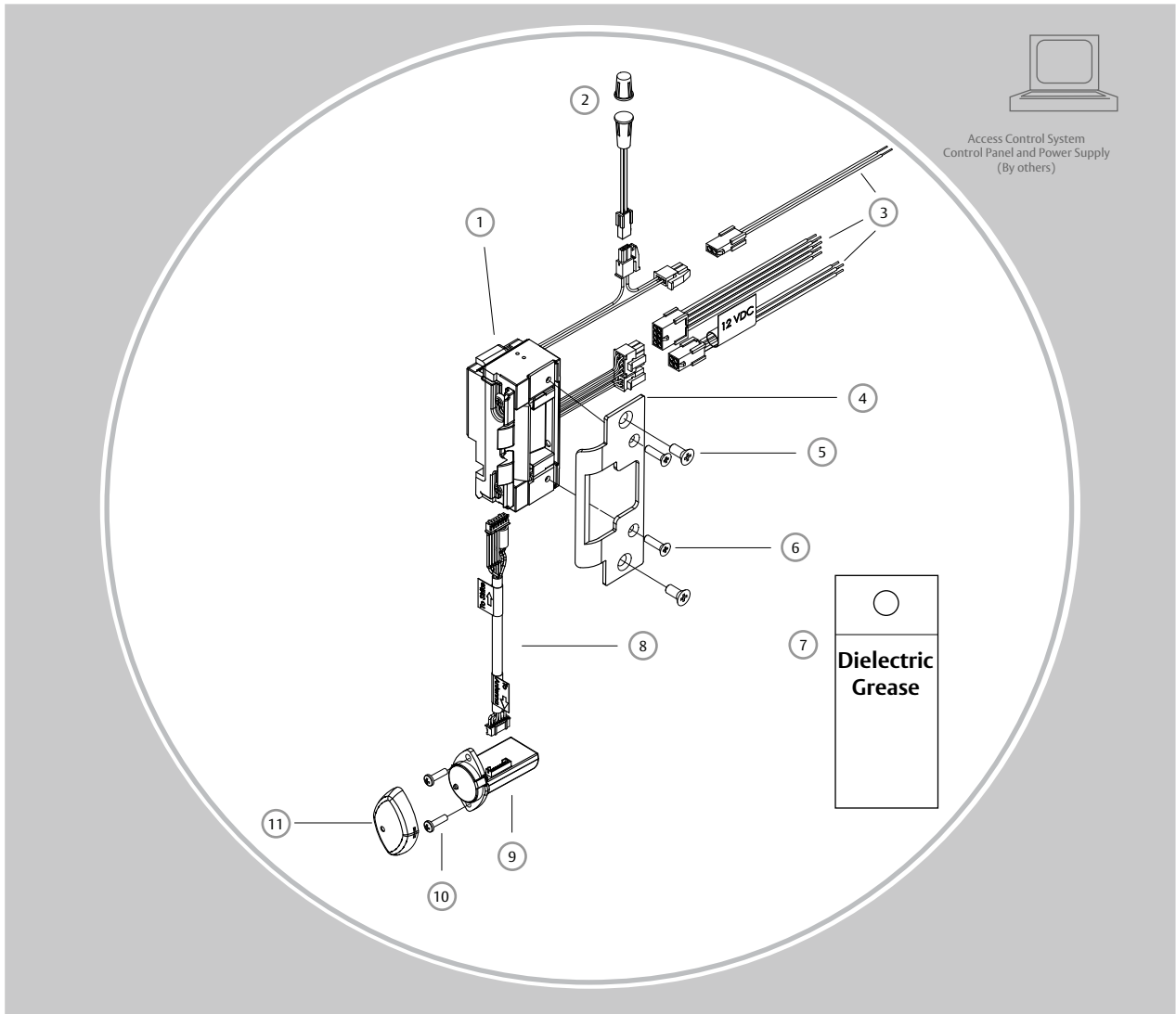

Wiring Diagram

8 Pin Connector (Reader Module)

Red	(+) Board Power
Black	(-) Board Power
Green	Data 0
White	Data 1
Yellow	LED/Buzzer
Blue	Not Used
Orange	Not Used
Brown	Not Used

2 pin Connector (Strike Module)

Tan	Common
Pink	Door Closed and Latch Engaged

2 Pin Connector (Door Position Switch)

Wire plugs into Hybrid Electric Strike

4 Pin Connector (Strike Module)

Red	(+)	Strike Power
Black	(-)	Strike Power

Installation Directions

RF8010/RF8310 EXTERNAL ANTENNA

3

CAUTION! Before connecting any device at the installation site, verify that there is 12VDC input voltage using a multimeter. Many power supplies and low voltage transformers operate at higher levels than listed. Any input voltage outside the electrical specifications outlined on page 1 may cause severe damage to the unit and will void the warranty. Also note that a linear power supply is recommended. Finally, this product contains electrostatic sensitive components. We recommend proper grounding techniques be observed during installation.

Evaluate Opening

1. Verify opening is plumb and square. For important detail, see "Read Me" guide.

Prepare Frame

2. Remove the dustbox and prepare door jamb for hybrid electric strike per the appropriate template detail (see pages 5-7). Be sure to allow enough room behind the strike in the cutout to avoid pinching any wires.

3. Drill a 1" diameter hole for reader/antenna per the appropriate template detail (see pages 5-7). Note that the reader/antenna may be positioned as desired, within limits of the 24" cable. If necessary (e.g. wood frames), drill a channel from the reader/antenna to the hybrid electric strike to accommodate the 24" cable.

4. Drill a 3/8" hole for the door position switch per the appropriate template detail (see pages 5-7). Note that the door position switch may be positioned as desired, within limits of its 10" connector. If necessary (e.g. wood frames), drill a channel from the door position switch to hybrid electric strike to accommodate the 10" cable. Next, drill a matching 3/8" hole in the door and install the press-fit magnet so that it will contact with the door position switch.

Prepare Strike

5. Verify that the strike is in the correct mode of operation. This unit ships in fail secure mode. If you need to convert to fail safe, see page 8.

6. Attach the faceplate to the electric strike, using the #8-32 screws provided. Be sure that the ramps are on top of the faceplate (see page 4). Temporarily install in frame.

7. The deadlatch must not interfere with the RF8010/RF8310 ramps (see page 4). Mark the centerline of the deadlatch onto the RF8010/RF8310 faceplate. Remove the RF8010/RF8310 hybrid strike from the jamb. Loosen screws and slide the internal ramp until the groove between the ramps aligns with the mark made on the faceplate. Tighten the screws after any adjustment is made.

Connect Components and Wiring

8. Check that the wires running from the host control panel are adequate wire gauge for the components and distance (see Wire Gauge Diagram below). Connect the wire leads of the three pigtailed provided to the host control panel wiring based on the wiring diagram on page 2 and the appropriate termination at the host control panel.

9. Mount the door position switch (DPS) into the frame. Route the 10" cable back to the electric strike and connect it to the 2 pin connector coming out of the hybrid electric strike. It does not matter which 2 pin connector is used. Note: the LBM & DPS are wired in series--a 'closed' electrical circuit depicts a closed door and extended latchbolt into the hybrid electric strike.

10. Attach the 8, 4 and 2 pin connectors at the hybrid electric strike to the equivalent pigtail connectors routed from the host control panel. Apply grease to the pigtail electrical terminals if used in a humid environment

11. Connect the 24" cable to the reader/antenna (check labels to insure that you connect the correct end). Then, install the reader/antenna in the frame, using the #6-32 screws provided. Snap on the reader/antenna cover and pull the 24" cable through to the hybrid electric strike.

12. Plug the loose end of the 24" cable into the connector on the side of the hybrid electric strike.

Finish Installing

13. Re-install the hybrid electric strike unit in jamb cutout, using #12-24 screws provided (or wood screws where necessary).

14. If applicable, tighten the #10-32 screws holding the mounting tabs.

15. If opening is not plumb and square, see "Read Me" guide for recommended corrections.

Testing and Operation

16. When power is supplied to the hybrid electric strike, the LED will flash green three times, while the beeper simultaneously beeps. The LED will then turn red. This sequence indicates that the micro-controller is operating properly.

17. Present a Proximity ID card to the reader/antenna. The LED will turn green, while the beeper beeps once. This indicates that the card was read successfully.

18. Simultaneously, the keeper will click open. This indicates that communication between the host and the hybrid electric strike is operational.

19. For further testing of communication with the host, consult the manual for the control panel or the site's system administrator.

Preparation

RF8010/RF8310: EXTERNAL ANTENNA

FACEPLATE INSTALLATION

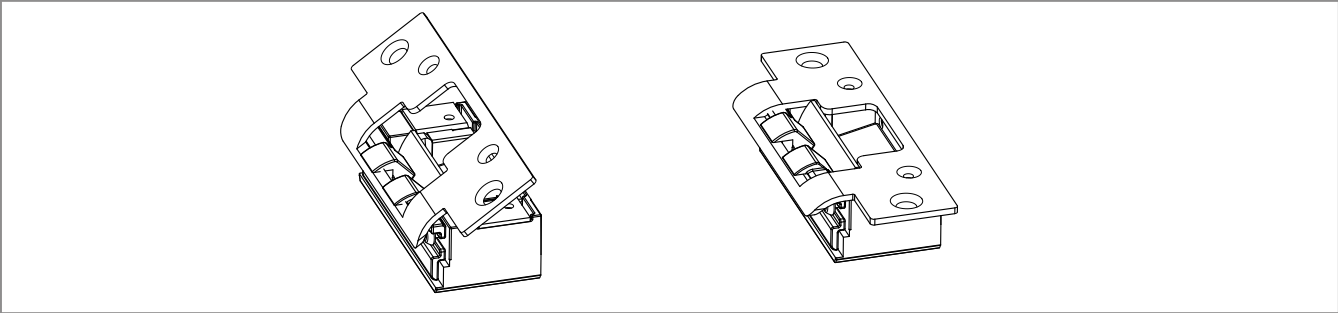

VERTICAL ALIGNMENT

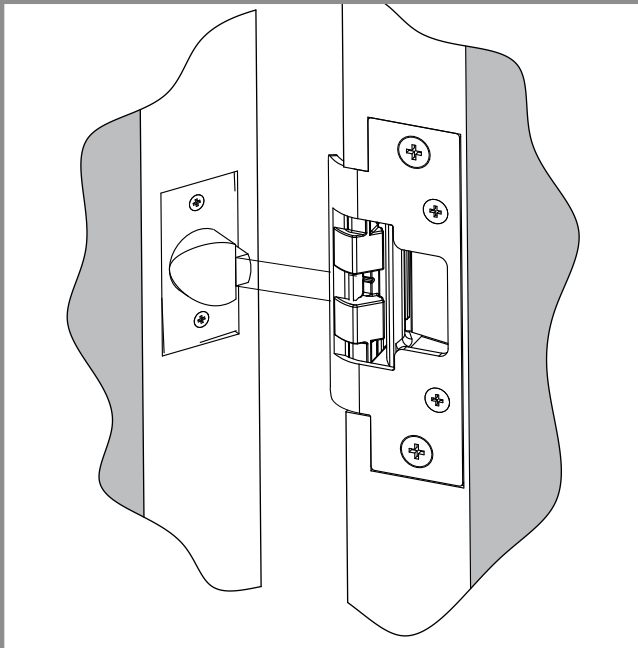

VERTICAL ADJUSTABILITY

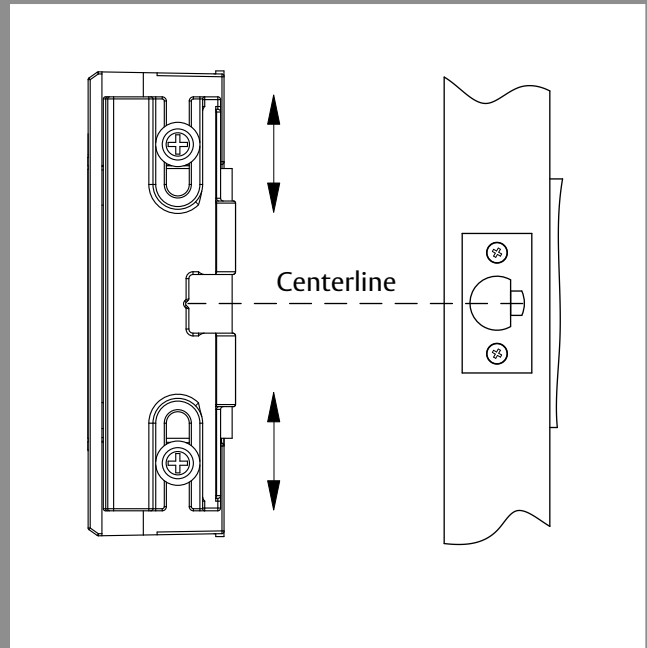

WIRE GAUGE DIAGRAM

12VDC @ 240 mA		
Max. One-way Distance	Voltage Drop/100'	Recommended AWG
800'	0.15	12 Gauge
500'	0.24	14 Gauge
300'	0.38	16 Gauge
200'	0.61	18 Gauge
120'	0.97	20 Gauge
100' or less	1.53	22 Gauge

Cutout Templates

RF8010/RF8310: EXTERNAL ANTENNA

RF8010/RF8310 with 801 Faceplate

1-1/4" x 4-7/8" Square Corner Faceplate
ANSI Metal Jamb Installations

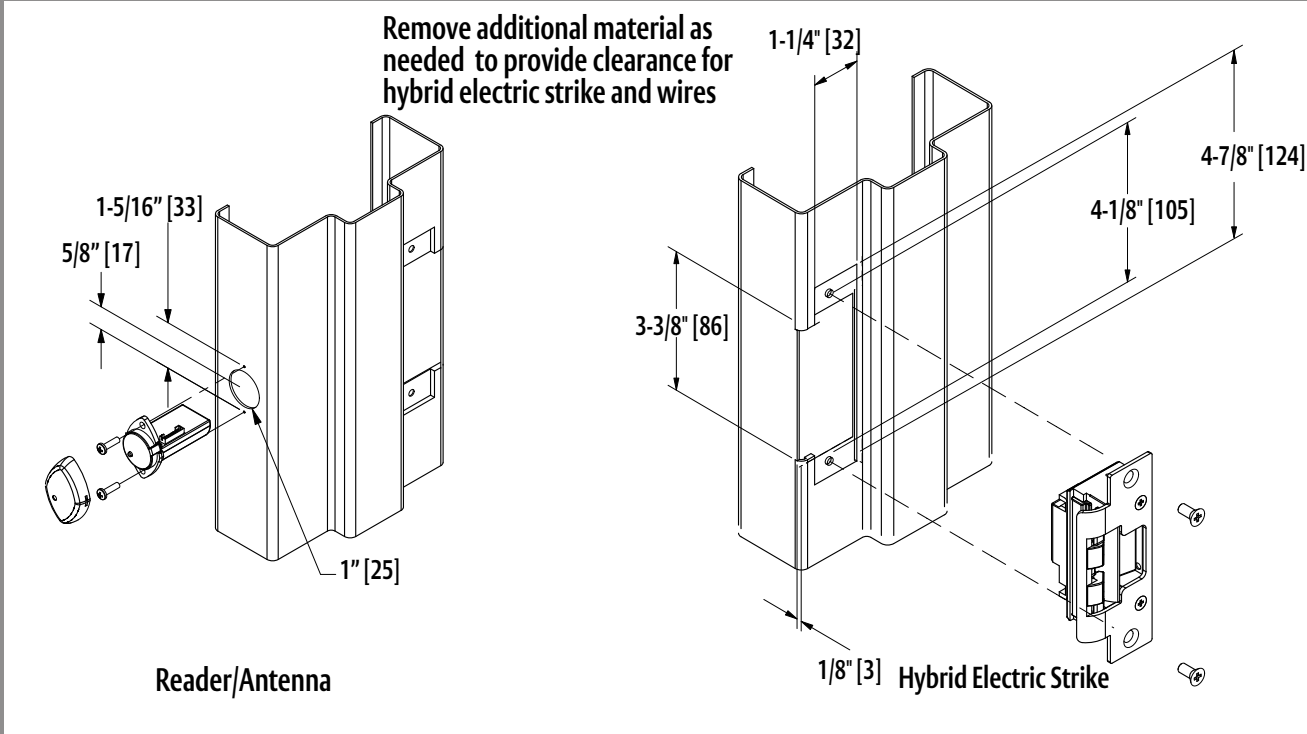

RF8010/RF8310 with 801-A Faceplate

1-1/4" x 4-7/8" Radius Corner Faceplate
Aluminum Jamb Installations

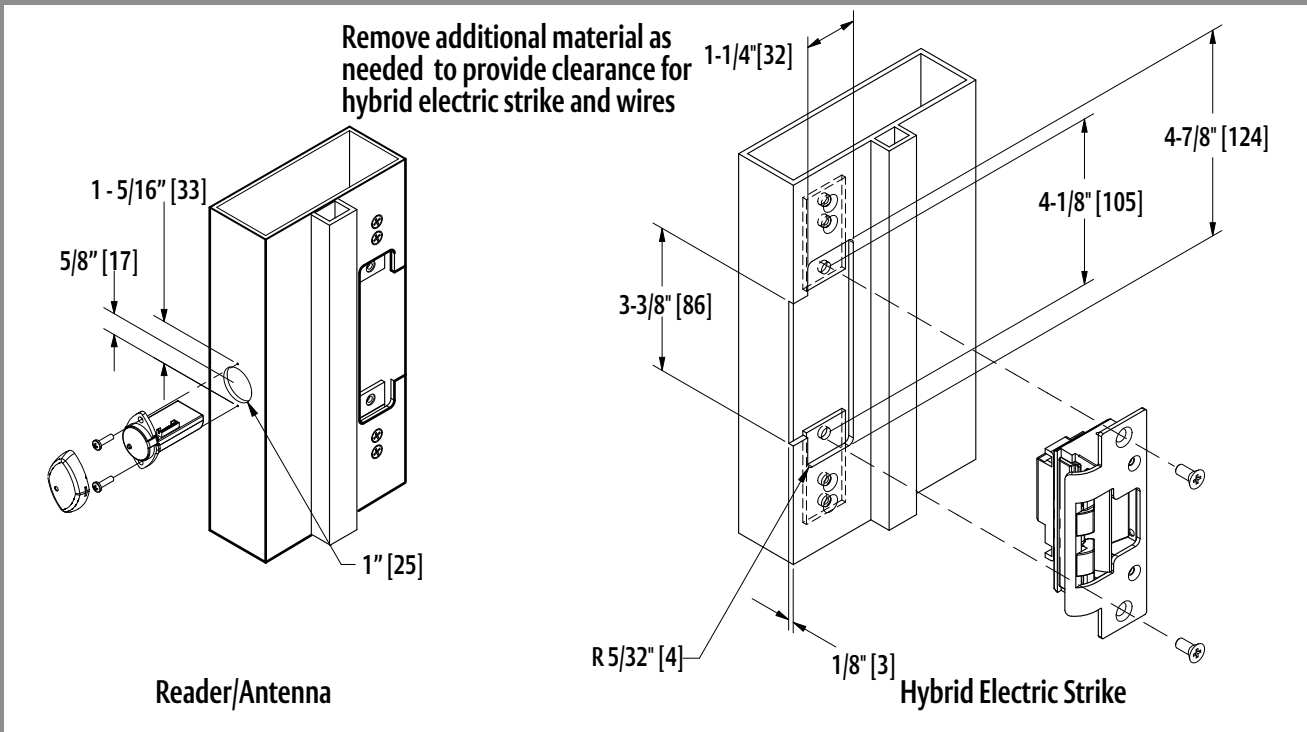

Cutout Templates

RF8010/RF8310: EXTERNAL ANTENNA

RF8010/RF8310 with 802 Faceplate

1-7/16" x 7-15/16" Radius Corner Faceplate
Aluminum and Wood Jamb Installations

Remove additional material as needed to provide clearance for 1-7/16" [36.5] hybrid electric strike and wires

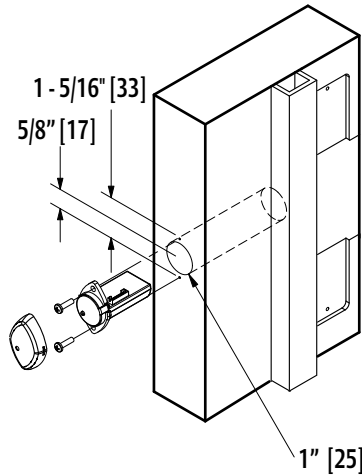

Reader/Antenna

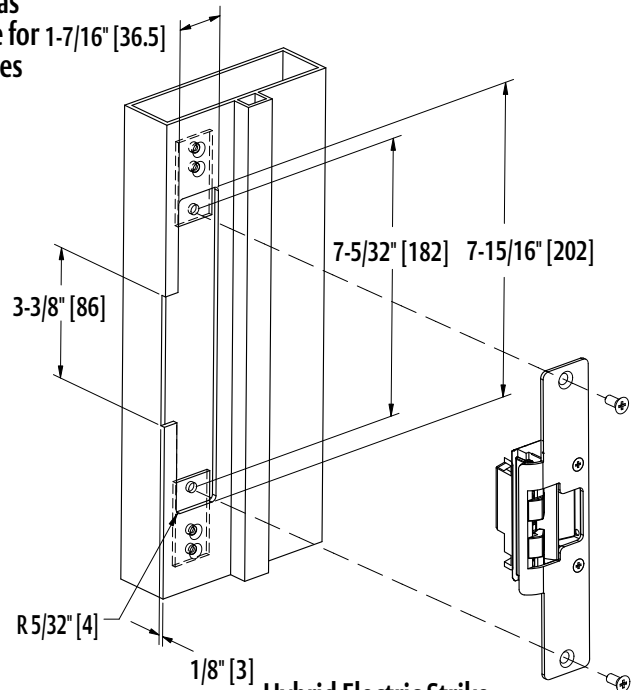

Hybrid Electric Strike

RF8010/RF8310 with 803 Faceplate

1-1/4" x 6-7/8" Radius Corner Faceplate
Aluminum Jamb Installations

Remove additional material as needed to provide clearance for hybrid electric strike and wires

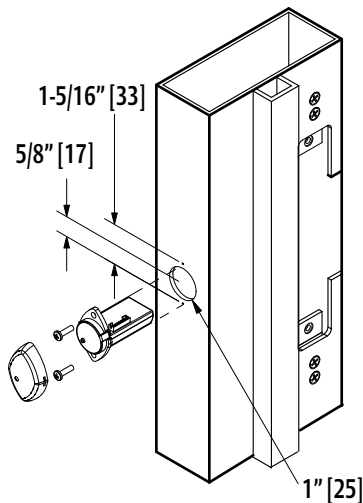

Reader/Antenna

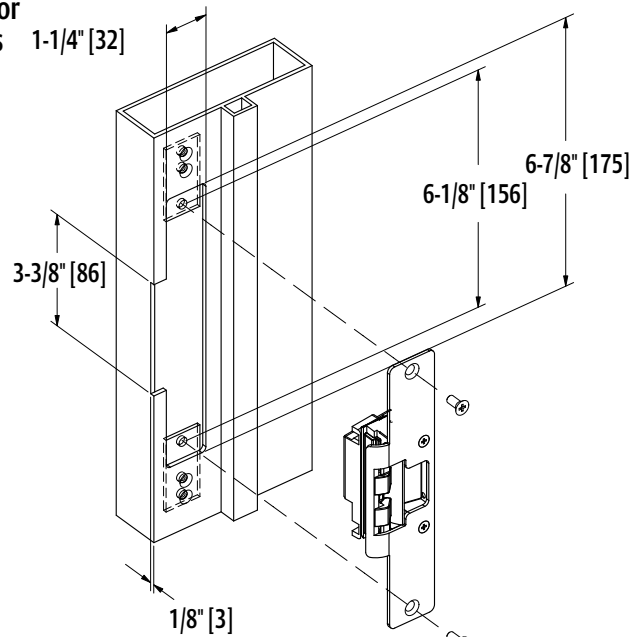

Hybrid Electric Strike

Cutout Templates

RF8010/RF8310: EXTERNAL ANTENNA

7

RF8010/RF8310 with 805 Faceplate

1-3/8" x 9" Radius Corner Faceplate

Aluminum or Wood Jamb Installations

Remove additional material as needed to provide clearance for hybrid electric strike and wires

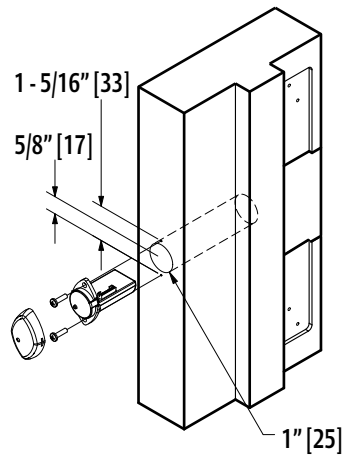

Reader/Antenna

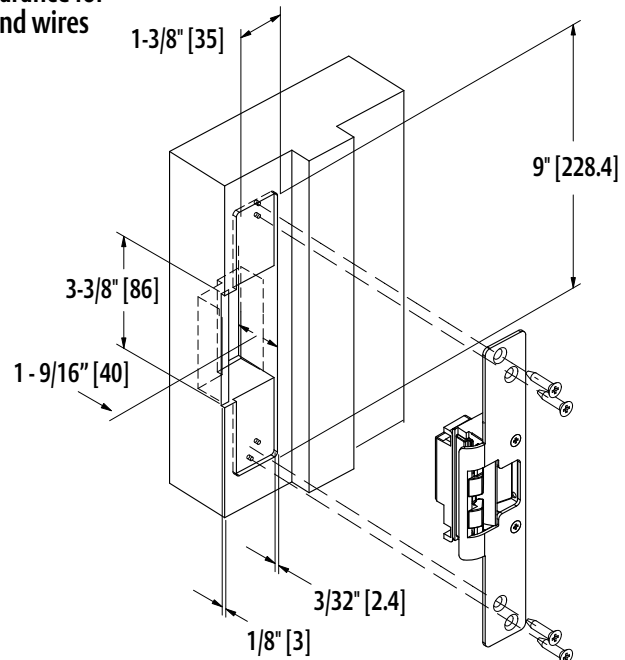

Hybrid Electric Strike

Warning: Changes or modification to this device not expressly approved by HES, Inc., could void the user's authority to operate the equipment.

NOTE: This equipment has been tested and found to comply with the limits for a class [B] digital device, pursuant to Part 15 of the FCC Rules. These limits are designed to provide reasonable protection against harmful interference in a residential installation. This equipment generates, uses, and can radiate radio frequency energy and, if not installed and used in accordance with the instructions, may cause harmful interference to radio communications. However, there is no guarantee that interference will not occur in a particular installation. If this equipment does cause harmful interference to radio or television reception, which can be determined by turning the equipment off and on, the user is encouraged to try to correct the interference by one or more of the following measures:

- Reorient or relocate the receiving antenna.
- Increase the separation between the equipment and receiver.
- Connect the equipment into an outlet on a circuit different from that to which the receiver is connected.
- Consult the dealer or an experienced radio/TV technician for help

This class [B] digital apparatus meets all requirements of the Canadian Interference Causing Equipment Regulations. Operation is subject to the following two conditions: (1) this device may not cause harmful interference, and (2) this device must accept any interference received, including interference that may cause undesired operation.

Cet appareillage numérique de la classe [B] répond à toutes les exigences de l'interférence canadienne causant des règlements d'équipement. L'opération est sujette aux deux conditions suivantes: (1) ce dispositif peut ne pas causer l'interférence nocive, et (2) ce dispositif doit accepter n'importe quelle interférence reçue, y compris l'interférence qui peut causer l'opération peu désirée.

Fail Safe Conversion

RF8010/RF8310: EXTERNAL ANTENNA

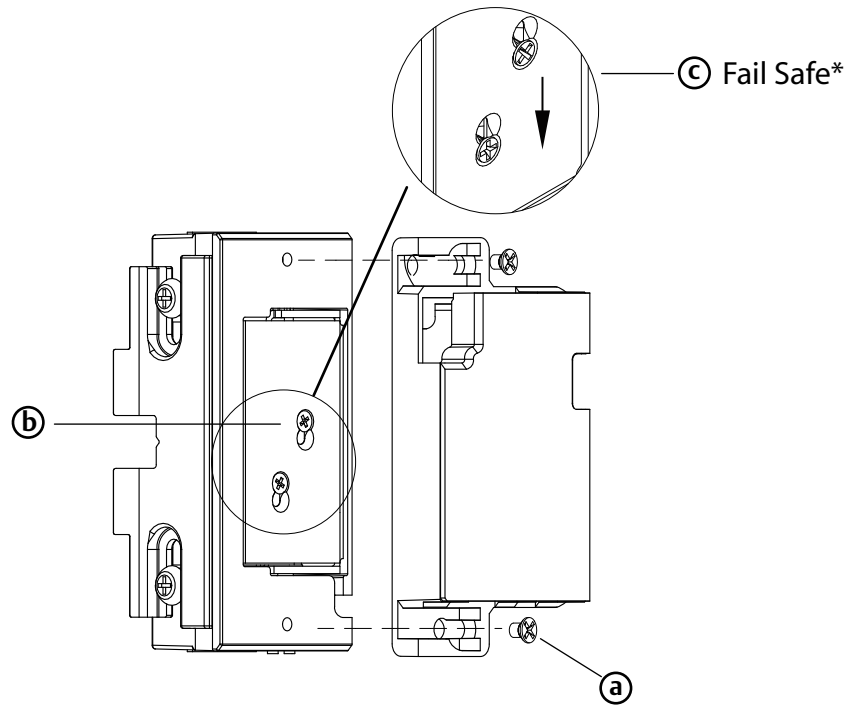

Remove Reader Module

a. In order to change the mode of operation from fail secure (standard) to fail safe, first detach the reader module by removing the two screws on the back of the hybrid electric strike.

Convert Mode

b. Loosen the two #2-56 screws located on the back of the strike module, as shown above, but do not remove them.

c. Move screws from the top of the hole to fail safe position.

d. Tighten screws.

Finish

e. Replace the reader module and tighten the two screws to hold it in place.

*Fire rating only applies to Fail Secure units. Conversion to Fail Safe negates fire rating.